

LABVIEW INTERFACED WIRELESS BLUETOOTH CONTROLLED VEHICLE

DEEPANSHU GUPTA

Graduate Student, Department of Electronics and Communication, PEC University of Technology,
Chandigarh, Punjab and Hariyana, India

ABSTRACT

This research paper is made with the objective of demonstrating the wireless communication which takes place with the help of bluetooth module between LabVIEW and a arduino controlled vehicle

KEYWORDS: Aruino Uno, Atmega 328, Hc-05 Bluetooth, Lithium Ion Battery

INTRODUCTION

There was a time when people used animals to locomote around. But with need of time things have completely changed. After the invention of wheel, the world of locomotion turned upside down. And even now we still play with the basics.

Keeping the ongoing advancements in technology in mind, we have made a project using LABVIEW, controlling a wireless car using Bluetooth technology. Also wireless communication is the latest technology, via which most of the communication is taking place. LABVIEW created by National Instruments is an excellent software for data acquisition.

OBJECTIVE

In this project we take the input from the keyboard and process the data and send the data through serial communication using Bluetooth technology to the Arduino board which then run the motors of the car.

In the hardware section, the major part is the car which will be controlled by the Arduino microcontroller board, a motor driver L293-D, and 12V lithium-ion battery pack.

IMPLEMENTATION

In the software section, we have used LABVIEW to create our program by which we are able to control our wireless car.

The following are the list of LABVIEW functions used:

- Visa Create
- Initialize Keyboard
- Query Input Device
- Acquire Input Data
- Insert Into Array

- Flatten Into String
- Indicators
- Stop Control
- Visa Write

HARDWARE

- The hardware consisted of the following materials:
- Four DC Motors
- HC-05 Bluetooth module
- Arduino board
- Acrylic sheet for chassis
- L293D motor driver
- 12V lithium ion battery
- Four Tires

CODE

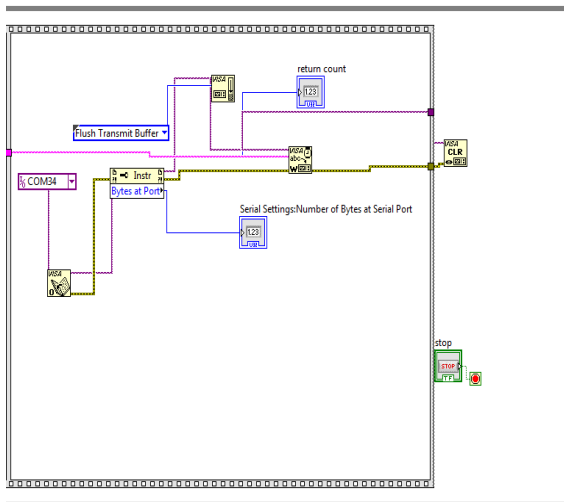

Figure 1

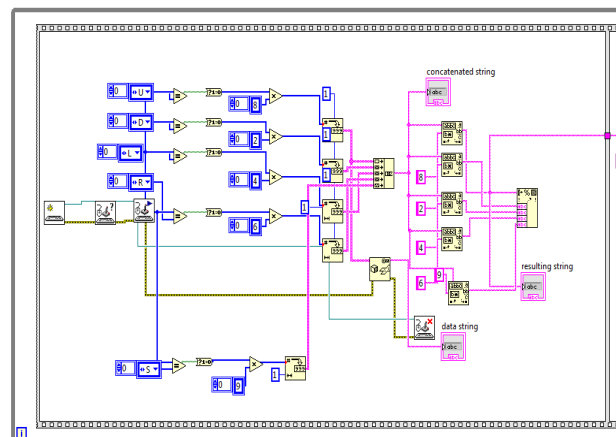

Figure 2

FUTURE SCOPE

Our car can act as a base model for other scientific researchers, who will not only enhance the hardware & software but also modify it for various applications which will in turn help the mankind.

It can be best used in space missions where the environment is hostile to humans. A lot of expense can also be saved in turn.

In military operations where entering enemy's radar can be last thing to do in person, that's where our car can plant a bomb or send live feedback from behind the lines while it is camouflaged.

CONCLUSIONS

Basically what we are trying to create is a model which will not only be helpful for us but will also be used in future. It would act as a research model wherein, the hardware parts can be updated with the latest technology, sensors attached to the bot so that it can send real time info, video feed, long range communication devices be included. So we can sit at one place and control and send the robot car anywhere.

One of the best features of LABVIEW is that it not only acquires various kinds of data and inputs from devices but also plots and presents us in a very interesting manner. So that we have all the info at one place and the same time.

ACKNOWLEDGEMENTS

I am sincerely grateful to my department Electronics and Communication Engineering Department, PEC University of Technology, Chandigarh, for providing me with the necessary recourses to complete this project.

I am very grateful to my family, who whose support has been never ending.

I am also thankful to all my professors & friends for correcting me along the way and providing valuable suggestions.

REFERENCES

1. www.instructables.com
2. www.wikipedia.com
3. www.google.com
4. www.ni.in
5. http://makezineblog.files.wordpress.com/2014/03/hc_hc-05-user-instructions-bluetooth.pdf
6. www.howstuffworks.com
7. EModuletechnologysolutions

